

Clarke®



SUBMERSIBLE WATER PUMP

MODEL NO: CSE400A

PART NO: 723100

OPERATION & MAINTENANCE INSTRUCTIONS



ORIGINAL INSTRUCTIONS

GC0221 rev 3

INTRODUCTION

Thank you for purchasing this CLARKE submersible pump.

This highly efficient pump is designed for pumping clean water only, please see Features, page 5), and are ideally suited for draining ponds, pools, building excavations etc, where water temperature does not exceed 35°C.

These pumps are NOT suitable for pumping salt water, or for permanent installation in fish ponds as the acidity, found in fish ponds, will damage the pump seals.

These pumps are fitted with a thermal overload switch. If the pump overheats for any reason, it will automatically switch the pump OFF. Once the pump has cooled (at least 5-10 minutes), the pump will automatically restart.

Before attempting to operate your pump, please read this instruction manual thoroughly and follow all directions carefully. This is for your own safety and that of others around you, and to help you achieve long and trouble free service from your pump.

GUARANTEE

This product is guaranteed against faulty manufacture for a period of 12 months from the date of purchase. Please keep your receipt which will be required as proof of purchase.

This guarantee is invalid if the product is found to have been abused or tampered with in any way, or not used for the purpose for which it was intended.

Faulty goods should be returned to their place of purchase, no product can be returned to us without prior permission. This guarantee does not effect your statutory rights.

ENVIRONMENTAL RECYCLING POLICY



Through purchase of this product, the customer is taking on the obligation to deal with the WEEE in accordance with the WEEE regulations in relation to the treatment, recycling & recovery and environmentally sound disposal of the WEEE.

In effect, this means that this product must not be disposed of with general household waste. It must be disposed of according to the laws governing Waste Electrical and Electronic Equipment (WEEE) at a recognised disposal facility.

SAFETY INSTRUCTIONS

GENERAL

1. Read all instructions before use and save these instructions for future use.
2. An approved residual current device (RCD) which has a tripping current of less than 30mA **MUST** be used for all operations.
3. The electrical supply must be the same as that on the rating plate.
4. Always make sure that your hands are dry when connecting or disconnecting from the mains supply.
5. Never pull the mains lead to disconnect the pump from the mains socket.
6. The mains plug must be kept away from the water at all times.
7. Do not allow children or unauthorised people to touch the pump, cables or connections.
8. Disconnect the pump from the mains supply when not in use.
9. If necessary have the pump repaired by a qualified person.
10. Keep the mains lead away from heat, oil and sharp edges.
11. If you have to use an extension lead with this product, it must be designed for outdoor use and incorporate a cable suitable for use with Class I appliances.
12. Disconnect the pump from the electrical supply and wear gloves during servicing or maintenance.

PUMP SPECIFIC

1. Do not pump explosive / flammable liquids or chemicals.
2. Never allow the pump to run dry or operate out of the water.
3. Submersible pumps should always be submerged and stored vertically.
4. Disconnect the pump from the mains supply before placing it into or removing it from the water.
5. Always check the plug, and all cables for damage before use.
6. Do not use the pump if damaged. Refer to qualified service personnel for repair.
7. Never carry or lower the pump by the power cable or float switch always use the handle or a rope tied securely to the handle.
8. Never insert your fingers into the pump whilst it is connected to the mains.
9. Never use the submersible pump in a swimming pool when there are people or animals in the pool.
10. Keep the pump clear of any sediment by standing it on a platform or brick or suspending it at a suitable depth.
11. Do not use the pump if the water is liable to freeze, as this can cause damage to the pump. Remove the pump from the water and store it in a frost free location.

ELECTRICAL CONNECTIONS



WARNING: READ THESE ELECTRICAL SAFETY INSTRUCTIONS THOROUGHLY BEFORE CONNECTING THE PRODUCT TO THE MAINS SUPPLY.

Connect the mains lead to a standard, 230 Volt (50Hz) electrical supply through an approved 13 amp BS 1363 plug, or a suitably fused isolator switch. If the plug has to be changed because it is not suitable for your socket, or because of damage, it must be removed and a replacement fitted, following the wiring instructions shown below. The old plug must be discarded safely, as insertion into a power socket could cause an electrical hazard.



**WARNING: THE WIRES IN THE POWER CABLE OF THIS PRODUCT ARE COLOURED IN ACCORDANCE WITH THE FOLLOWING CODE:
BLUE = NEUTRAL BROWN = LIVE YELLOW AND GREEN = EARTH**

If the colours of the wires in the power cable do not agree with the markings on the plug.

- The BLUE wire must be connected to the terminal which is marked N or coloured black.
- The BROWN wire must be connected to the terminal which is marked L or coloured red.
- The YELLOW AND GREEN wire must be connected to the terminal which is marked E or \perp or coloured green.

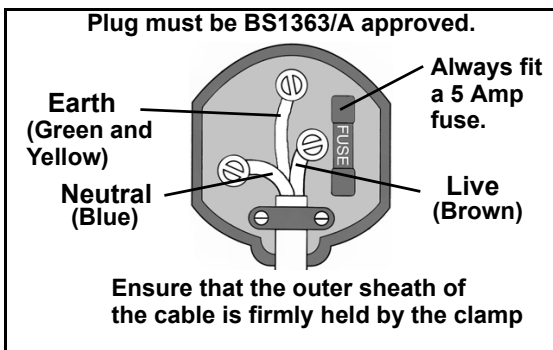

AN APPROVED RESIDUAL CURRENT DEVICE (RCD) WHICH HAS A TRIPPING CURRENT OF LESS THAN 30 mA MUST BE USED.

If you are not sure, consult a qualified electrician. DO NOT try to do any repairs.

FEATURES

This pump is of rugged and durable construction, designed for long lasting operation and its plastic body provides good anti corrosive properties. The motor is provided with built in overload protection.

For your information the chart, on page 9 shows the flow rate for the pump at various heads. HEAD is the distance, or height, from the surface of the water to the point of discharge)

This pump is designed to pump clean water such as fish ponds, swimming pools, flooded cellars etc.

IMPORTANT: The Pump is NOT designed for pumping slurry, sludge, mud or heavily polluted water, and should NOT be used for permanent installation in fish ponds or any water containing chemicals or other acidic contaminants including salt water.

Whenever the pump is used to pump contaminated water, e.g. to drain fish ponds etc., you must ALWAYS immerse it in clean water and run it for a few minutes on completion, to ensure it is completely cleansed of all contaminants.

The maximum depth to which this pump should be submerged is 8 Metres.

This pump is suitable for permanent or semi-permanent installations, e.g. installations where it is necessary to maintain a water at a particular level.

As the water level rises, so will the float. At a certain point the switch will operate and start the pump. As the water level falls, so will the float until the switch operates again and stops the pump.

You can adjust the level at which the pump cuts out by sliding the float switch cable through the slots in the handle.

Shorten or lengthen it as required. The shorter it is, the earlier the pump will cut out, and the water therefore will be deeper at this point. Similarly, it will cut in earlier and the water will therefore be shallower when it does so.

ALWAYS check its operation before use.

Theoretically, the pump will drain a sump down to a depth of 5mm, but this will depend upon the float switch setting.

You should never allow the pump to operate for longer than 10 minutes with the pump body exposed....that is....when the water level is below 70mm.

The pump is provided with a vent valve in order to prevent an air lock when plunging the pump into the water. It may take up to 1 minute before all air is expelled, once the pump is submerged

INSTALLATION & OPERATION

The pump is complete with an Outlet Hose Adapter which simply screws into the outlet port on the side of the pump body.

The adapter has three steps, providing the option for three different hose sizes to be used. (See specifications for details).

Please bear in mind, that if the pump is to be used for drainage purposes, or in situations that demand maximum efficiency, you should ALWAYS connect the largest diameter hose possible to the outlet hose adapter, as small diameter hoses reduce capacity and put additional strain on the motor.

Once you have decided upon a suitable hose size, the smaller diameter steps of the adapter should be cut off, so as not to cause an obstruction to flow. If you subsequently need to install a larger diameter hose, replacement adapters are available from your Clarke dealer.

Ensure the hose is secured with a suitable worm drive clip (not supplied).

The pump is completely submersible and must be placed in a vertical position on a solid flat surface. If this is not available, sit the pump on house bricks, or something similar, and ensure that this type of support is not likely to shift.

The pump should be well clear of silt, mud or any type of marine growth.

IMPORTANT: ALWAYS raise and lower the pump using a rope attached to the handle, NEVER by the power cable or float switch cable.

Ideally the pump should be placed in a sump which has adequate dimensions so as not to restrict the movement of the float switch.

Please note that the symbol V on the pumps' Rating Plate, denotes the **MAXIMUM** depth to which the pump may be submerged, in metres.

With the pump properly installed, and taking all necessary precautions as described on page 3, plug in to the mains supply, and switch ON.

NOTE: If the pump does not deliver immediately, it is possible that an air lock exists. Leave the pump for approximately one minute in order for air in the pump to vent through the vent valve. If necessary, switch ON and Off again in order to assist the venting process.

SUITABLE HOSE, and SPARE/REPLACEMENT HOSE ADAPTERS ARE AVAILABLE FROM YOUR CLARKE DEALER



CAUTION: THE WATER BEING PUMPED WILL BE POLLUTED IF THIS PUMP BECOMES DAMAGED AND LUBRICANT WITHIN THE PUMP ESCAPES.

SETTING UP AND USING THE PUMP

POSITIONING THE PUMP

1. Place the pump on a flat surface in the area that you want to drain.
 - If there is sediment in the operating area, the pump should be placed vertically on house bricks or similar.
 - Ensure the pump is positioned with adequate space so that the movement of the float switch is not restricted - recommended minimum area of 50 x 50cm.
 - ALWAYS raise and lower the pump using a rope attached to the lifting handle.
 - Take all necessary precautions as described on page 3.

USING THE PUMP



WARNING: CHECK THE PUMP FOR DAMAGE BEFORE USE, DO NOT USE THE PUMP IF IT IS DAMAGED IN ANY WAY.

WARNING: THE WATER BEING PUMPED WILL BE POLLUTED IF THIS PUMP BECOMES DAMAGED AND LUBRICANT WITHIN THE PUMP ESCAPES.

1. Connect the mains plug to the mains supply.
 - Always use a high sensitivity residual current device (RCD) which has a tripping current of less than 30mA.
2. Switch the mains power supply on.
 - The pump will begin to drain water.
 - As the water level falls, so will the float switch, until it stops the pump.
 - You can adjust the position at which the float switch lead clips to the side of the pump. Adjusting the length of the float switch lead will change the depth of water at which the pump will turn on or off.
3. When pumping is finished, disconnect the pump from the mains power supply.

IMPORTANT: Do not allow the pump to run dry.

MAINTENANCE



WARNING: BEFORE CHECKING THE CONDITION OF THE PUMP, ENSURE IT IS UNPLUGGED FROM THE MAINS SUPPLY. IF THE UNIT IS HARD WIRED, ENSURE THE CIRCUIT BREAKER IS OPEN.

This pump should require no maintenance other than regular cleaning.

If the pump starts to show signs of wear or damage, contact your CLARKE dealer for advice. Do not use the pump if there is any damage to the mains supply cable, or to the float switch or its cable.

CLEANING

1. Check the pump installation regularly to ensure the water inlet is clear of leaves or other debris.
2. Take extra care to remove any debris from around the impeller.

NOTE: Do not attempt to repair the pump yourself, as you may damage the waterproof seal and invalidate your guarantee. Repairs must be carried out by your CLARKE dealer, or contact the CLARKE Service Department, on 020 8988 7400.

Note that the pump is fitted with an automatic thermal overload protection device. If the pump overheats due to an obstruction in the pump, or pumping warm water in excess of 35°C for example, it will shut off automatically. Switch the pump OFF and disconnect from the mains supply. Check for blockages and allow the motor to cool (at least 15 minutes) before attempting to restart.

NOTE: If the pump becomes badly clogged, back flush by removing the outlet hose adapter and directing a jet of clean water through the outlet port.

STORAGE

When the pump is not being used for extended periods, clean and dry it thoroughly and store in indoors. If the pump is left in water, it should be run at least once a week to prevent it from seizing up.

SPECIFICATIONS

Voltage	230V~50Hz
Outlet Thread Diameter	1.25" BSP
Outlet Hose Adaptor Diameter	1. 25mm (1.5")
	2. 19mm (3/4")
	3. 13mm (1/2")
Motor output	400 Watts
Maximum Head Height	8 m
Maximum Submersion Depth	8 m
Maximum Capacity (at zero head)	7M ³ /hr (115 L/min)
Maximum pressure	0.8 bar
Weight	4.3 kg
Cable Length	10 m (H05RN.F)
Dimensions (D x W x H)	305 x 155 mm

SPARE PARTS

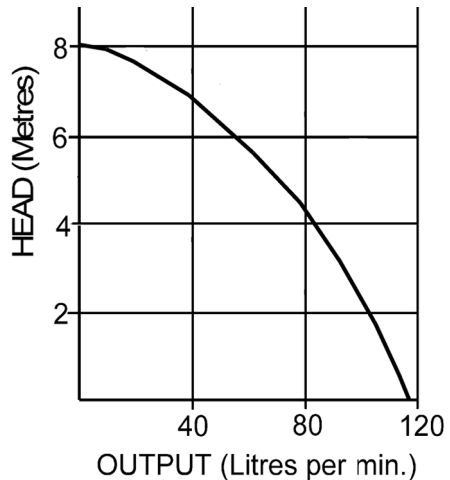
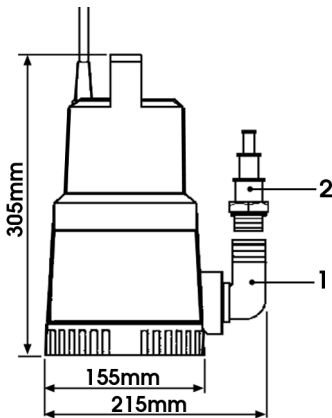

Replacement parts are shown in Fig.1. Elbow (1) and 3-stage Adaptor (2).

Please consult your local Clarke dealer or Clarke International Spare Parts Department.

TROUBLESHOOTING

PROBLEM	SOLUTION
PUMP WILL NOT START	<ol style="list-style-type: none"> 1. Make sure that the power is switched on. 2. Check fuse (consult an electrician if in doubt). 3. If an extension lead is fitted, check connections (consult an electrician if in doubt). 4. Internal thermal cut-out has not re-set. Leave for 5-10 minutes and try again. 5. The impeller may be jammed. Disconnect from the mains supply and remove any objects that may be obstructing the impeller. 6. Float switch may be jammed against side wall, or prevented from moving. 7. If the pump still fails to start, consult your CLARKE dealer for advice.
PUMP WILL START BUT NOT PUMP	<ol style="list-style-type: none"> 1. Check that the inlet is not blocked. 2. Check that the outlet is not clogged or obstructed. 3. The head may be too great, i.e. you are trying to lift the water too great a distance for the pump to cope with. 4. Air bubble in the pump, produced during immersion. immerse the pump again, at an angle, and shake it whilst lowering to remove any air trapped in the system. 5. Impeller may be damaged - Consult your CLARKE dealer.
PUMP WILL NOT STOP	<ol style="list-style-type: none"> 1. Float switch may be prevented from moving to the fully down position. 2. Float switch may be faulty. Consult your CLARKE dealer for advice.
PUMP STOPS RUNNING	<ol style="list-style-type: none"> 1. Thermal overload has operated. Leave for 5-10 minutes and try again. 2. Pump has run dry, or float switch has cut in. 3. A foreign object has jammed the impeller.

If this does not solve your problem, please contact the Clarke service department.

DECLARATION OF CONFORMITY



Clarke[®]
INTERNATIONAL

Hemnal Street, Epping, Essex CM16 4LG

DECLARATION OF CONFORMITY

This is an important document and should be retained.

We hereby declare that this product(s) complies with the following directive(s):

2014/30/EU *Electromagnetic Compatibility Directive.*

2014/35/EU *Low Voltage Equipment Directive.*

2011/65/EU *Restriction of Hazardous substances.*

The following standards have been applied to the product(s):

EN 60335-1:2012+A11:2014, EN 60335-2-41:2003 +A1:2004 +A2:2010, EN 62233:2008,

EN 61000-3-3:2013, EN 55014-2:1997 +A1:2001 +A2:2008, EN 61000-3-2:2014,

EN 55014-1:2006+A1:2009+A2:2011, EN55014-2:2015.

The technical documentation required to demonstrate that the product(s) meet(s) the requirement(s) of the aforementioned directive(s) has been compiled and is available for inspection by the relevant enforcement authorities.

The CE mark was first applied in: 2004

Product Description: Submersible Water Pump
Model number(s): CSE400A
Serial / batch Number: N/A
Date of Issue: 28/02/2018

Signed:

J.A. Clarke
Director

A SELECTION FROM THE VAST RANGE OF

Clarke®

QUALITY PRODUCTS



AIR COMPRESSORS

From DIY to industrial, Plus air tools, spray guns and accessories.

GENERATORS

Prime duty or emergency standby for business, home and leisure.

POWER WASHERS

Hot and cold, electric and engine driven - we have what you need

WELDERS

Mig, Arc, Tig and Spot. From DIY to auto/industrial.

METALWORKING

Drills, grinders and saws for DIY and professional use.

WOODWORKING

Saws, sanders, lathes, mortisers and dust extraction.

HYDRAULICS

Cranes, body repair kits, transmission jacks for all types of workshop use.

WATER PUMPS

Submersible, electric and engine driven for DIY, agriculture and industry.

POWER TOOLS

Angle grinders, cordless drill sets, saws and sanders.

STARTERS/CHARGERS

All sizes for car and commercial use.

PARTS & SERVICE:

0208 988 7400

Parts Enquiries

Parts@clarkeinternational.com

Servicing & Technical Enquiries

Service@clarkeinternational.com

SALES: UK 01992 565333 or Export 00 44 (0)1992 565335

Clarke INTERNATIONAL Hemnall Street, Epping, Essex CM16 4LG
www.clarkeinternational.com